

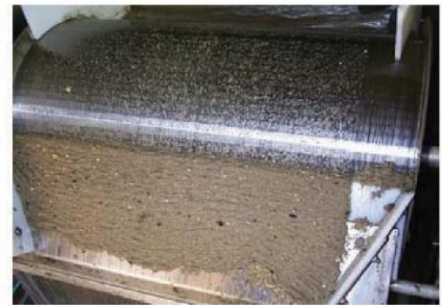

EXTERNALLY FED ROTARY DRUM SCREENS

For the removal of suspended solids from process and wastewater streams



Features

- Screen cylinder of helical-wound wedge wire
- Screen slot openings 0.005" to 0.250" for a variety of applications
- Screen assembly complete with internal support(s), tie rods, end rings, hub and shafts
- Influent headbox designs to handle pumped or gravity flow feed, complete with flow dampening weir(s)
- Influent overflow bypass piping

Chassis designs for open or enclosed filtrate discharge
Internal CIP manifold assembly with sprays designed for high pressure cleaning
Solids discharge blade assembly of UHMW construction
Shaft mounted, variable speed drives
All metal components of stainless steel construction



The chart on the back side of this brochure is not all inclusive and only shows examples, not all of available sizes, due to the fact that every screen is individually designed and sized based on each client's need.

RDS Features

- 1 Inlet
- 2 Head box
- 3 Wedge-wire drum
- 4 Doctor blade
- 5 High pressure spray
- 6 Drive motor

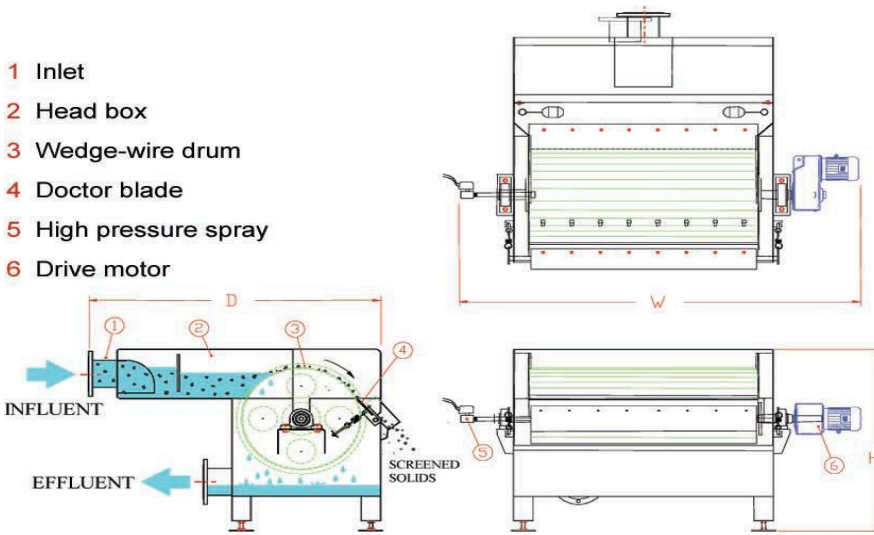

Technical Data

Model No.	Openings In 0.005" increments	Width W	Height H	Depth D	Clean Water Flow In GPM
RDS-1212	0.005—0.050	28"	16"	30"	0-30
RDS-1224	0.005—0.050	40"	16"	30"	0-50
RDS-2512	0.010—0.200	45"	45"	63"	160-485
RDS-2524	0.010—0.200	57"	45"	63"	325-1,025
RDS-2536	0.010—0.250	80"	45"	63"	487-1,445
RDS-2548	0.010—0.250	91"	45"	63"	665-1,865
RDS-2560	0.010—0.250	124"	45"	63"	825-2,285
RDS-2572	0.010—0.250	157"	45"	63"	995-2,705
RDS-2584	0.010—0.250	190"	45"	63"	1,150-3,125
RDS-2596	0.010—0.250	223"	45"	63"	1,320-3,545
RDS-3648	0.010—0.250	91"	57"	86"	1,325-4,205
RDS-3660	0.010—0.250	124"	57"	86"	1,645-5,253
RDS-3672	0.010—0.250	157"	57"	86"	1,965-6,300
RDS-3684	0.010—0.250	190"	57"	86"	2,285-7,349
RDS-3696	0.010—0.250	223"	57"	86"	2,605-8,397
RDS-36108	0.010—0.250	256"	57"	86"	2,925-9,445
RDS-36120	0.010—0.250	289"	57"	86"	3,245-10,500
RDS-36144	0.010—0.250	321"	57"	86"	3,565-11,548

Dontech Industries History

Founded in 1980, Dontech Industries, Inc. offers decades of engineering and design of screens, screening systems, belt presses and solids conveyance systems.

With its own team of experienced machine operators/welders each screen is individually constructed and sized based on the client's needs. This professional team allows for ease of construction of equipment that is unique in shape, size, or other design considerations.

Offering experience on both the industrial and municipal markets, our professionals have the knowledge that allows all pertinent design questions to be addressed, assuring the final screen meets the design application and specifications.

Externally Fed Screens

Externally Fed Screens are individually designed to meet the client's needs with regard to headbox configuration, inlets/outlets, height, width, pumped or gravity flow, etc.

All externally fed screens are equipped with overflow bypass provisions, located to suit the client's needs, eliminating overflow concerns.

All stainless steel construction featuring a fully chassis legs, pans, and other extraneous parts with no hidden add-on costs.

The wedge wire screen with variable slot opening provides solids removal based on client's specific particle size distribution.

Each system is equipped with an integral sump which can be oversized and/or conformed to meet design and potential upset conditions.

Externally fed screens are equipped with high pressure, CIPable spray manifold systems which can be run automatically or with manual operation.

For Food Applications: USDA approved, with a design that allows for the entire screen to be CIPed.

Screening systems are offered with a wide range of electrical control panel options, from basic to sophisticated control circuitry.

Additionally, spares and replacement parts are available, assuring years of uninterrupted service.