



## DON PRESS - BELT FILTER PRESSES

*For industrial and Municipal sludge dewatering*



### Features

- Independent dual-belt system
- Self-cleaning belt wash nozzles which allow the use of recycled water
- Pneumatic belt tracking and tensioning
- Frame and guards constructed of Type-304 stainless steel
- Available as a stand-alone press or as part of a complete system, which includes a polymer blend system, flocculation system, sludge pump, belt wash pump, air compressor, and controls
- Built in the USA

### Standard Don Press Belt Press Models

Model	Belt Width (m)	Total Belt Filter Area (ft <sup>2</sup> )	Dimensions* (LxWxH, in)	Capacity (gpm)	Wash Water Flow (gpm)	Weight* (lb)
500	0.5	41.5	102 x 38 x 72	4 - 22	15	1,100
800	0.8	70.2	102 x 50 x 72	14 - 40	24	1,300
1000	1.0	89.0	102 x 57 x 72	26 - 58	29	1,600

\*Dimensions and weights are for press only and exclude skids, sludge conditioning tanks, polymer tanks, and control panels

76 Center Drive Gilberts, IL 60136 Phone 847-428-8222 Fax: 888-314-9068

[www.dontechindustriesinc.com](http://www.dontechindustriesinc.com)

## Don Press Belt Press Features

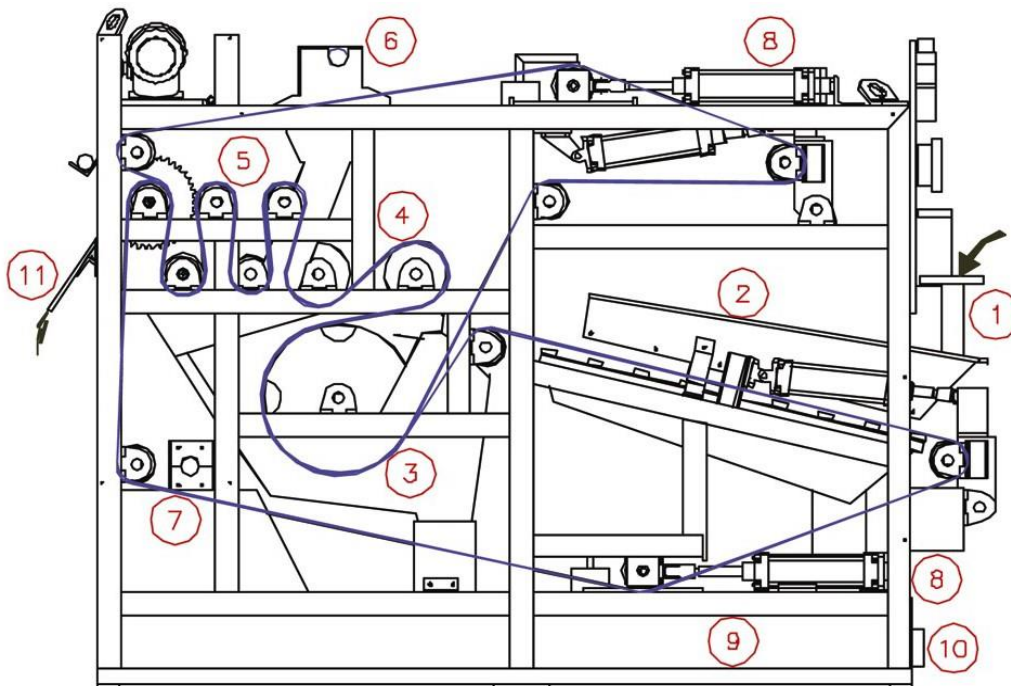

- 1 Sludge inlet
- 2 Gravity dewatering zone
- 3 Low pressure perforated dewatering roller
- 4 Medium pressure dewatering rollers
- 5 High pressure dewatering rollers
- 6 Upper belt washing device
- 7 Lower belt washing device
- 8 Belt tracking devices
- 9 General drain pan
- 10 Filtrate outlet
- 11 Cake outlet

## Performance Data

Sludge Source	Inlet TS (%)	Cake TS (&%)	Dry Solids Loading Rate (lb/hr-m width)	Polymer Consumption (lb/dry ton)
Aerobically digested WAS	1 - 5	18 - 22	285 - 440	6 - 10
Anaerobic digester	3 - 6	18 - 28	330 - 550	4 - 12
Municipal primary sludge	3 - 6	22 - 32	330 - 615	2 - 6
Primary physical/chemical	3 - 6	22 - 32	330 - 700	4 - 10
Milk processing	1 - 3	12 - 18	165 - 220	6 - 10
Slaughterhouse	2 - 4	13 - 20	285 - 395	6 - 14
Paper mill	3 - 10	20 - 36	375 - 660	Data not available

*Note: The above data are derived from actual applications and are subject to variation.*

### About Dontech Industries, Inc.

Dontech Industries, Inc., established in 1980, offers decades of experience in the engineering and design of screens, screening systems, solids conveyance systems and belt filter presses. With its own team of highly experienced machine operators/welders each piece of equipment is individually constructed to the client's exacting needs.

Offering experience in both the industrial and municipal markets, our professionals have the knowledge that allows all pertinent design questions to be addressed, assuring the final equipment meets the design application and specifications.

**Also offering spare and replacement parts to assure years of uninterrupted performance.**

76 Center Drive Gilberts, IL 60136 Phone 847-428-8222 Fax: 888-314-9068

[www.dontechindustriesinc.com](http://www.dontechindustriesinc.com)