

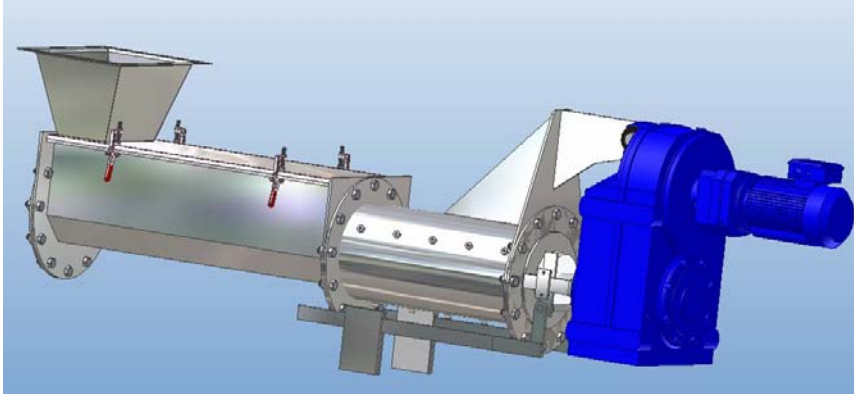

SCREENING WASHING/DEWATER SCREW PRESS



[Dontech Industries History](#)

Dontech Industries, Inc. offers more than 26 years experience in the engineering and design of screens, screening systems, and solids conveyance/compactor systems

With its own team of experienced machine operators/welders each Screw Compactor System is hand constructed to the clients exacting specifications. This professional team allows for ease of construction of equipment that is unique in shape, size, or other design considerations.

Offering experience on both the industrial and municipal markets, our professionals have the knowledge that allow all pertinent design questions to be addressed assuring the final System meets the design application.

Technical Data			
Model No.	Width	Height	Length
DWSP-9XX	14"	24"	8 to 10'*
			* Length can be longer as required

[Screenings Washing/Dewatering Screw Press](#)

Screw Press Systems are individually engineered and designed to meet client specifications with regard to location of influent solids collection hopper, height, width, gravity or pumped flow, and need for access/inspection doors.

Screw Presses are provided with drive system of variable speed design and are shaft mounted. System includes a flighting section, solids washing and compaction zones.

Systems are provided with mounting brackets and or support legs/frame of tubular design

All stainless steel construction including legs, trough, housing and other extraneous parts with no hidden add-on costs.

Screw Press Systems are offered with a wide range of electrical control panel options, from basic to sophisticated control circuitry.

Dontech Industries, Inc. 76 Center Drive Gilberts, IL 60136
Phone: 847-429-8222 Fax: 847-428-6855
www.dontechindustriesinc.com